



LUXPOINT® LED Tracklight - Eckhard

Datasheet



Colors:

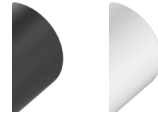

Black White



The Eckhard series delivers high-quality illumination for galleries, retail, and offices. Compatible with various track systems, it offers energy efficiency and easy installation. Benefits include enhanced visual appeal, improved ambiance, long-lasting performance, and cost-effective operation, making Eckhard ideal for accent and general lighting in diverse settings.

Benefits

- Versatile Lighting Options
- Highlight Your Favorites
- Easy Installation & Maintenance

Applications

- Living rooms
- Retail stores
- Restaurants
- Gallery
- Other demanding environments

LUXPOINT® LED Tracklight - Eckhard

Technical Data

Optical Specifications

Wattage		15W	25W	35W
Luminous Flux @CCT	3000K	1200lm	2000lm	2800lm
	4000K	1200lm	2000lm	2800lm
	6500K	1200lm	2000lm	2800lm
Total luminous flux of contained light sources @CCT	3000K	1320lm	2200lm	3080lm
	4000K	1320lm	2200lm	3080lm
	6500K	1320lm	2200lm	3080lm
Efficacy		90lm/W		
Flickering metric (Pst LM)		<1		
Stroboscope effect metric (SVM)		<0.4		
CRI		≥80		
SDCM		< 6		
Beam Angle		100°		
Photobiological safety group acc. To EN62778		RG0		
Photobiological safety group acc. To EN62471		RG0		
Dimmable		No		

Electrical and Mechanical Specifications

Input Voltage		220-240V ~50/60Hz		
Nominal Current		120mA	120mA	155mA
Inrush current time Th50		2.8µs@25A		
Power Factor		0.5	0.9	0.9
Max. number of luminaires per miniature circuit breaker	B16	29	29	30
	C10	23	23	24
	C16	37	37	38
Protection class		Class II	Class II	Class II
Dimensions		Ø58 x 126mm	Ø66 x 156mm	Ø78 x 180mm
Weight		290g	335g	490g
Housing		Die-cast aluminum		
Diffuser		Tempered glass		
Replaceable light source		No		
Replaceable Control gear		No		
Glow wire test according to IEC60695-2-12		650°C		

System Specifications

Power	AC mains
Operating Temperature	-10°C ~ 40°C
Storage Temperature	-20°C ~ 60°C
Lifespan L70/B50 at 45°C	15,000 hours
Lifespan L70/B50 at 25°C	30,000 hours
Number of switching cycles	50,000
Environment	Indoor
Safety Approval	CE, UKCA, RoHS
Mercury content	0.0mg
Warranty	3 years

LUXPOINT® LED Tracklight - Eckhard

Dimension

15W

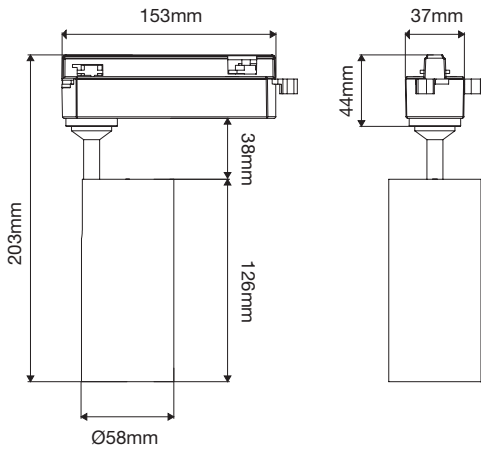

25W

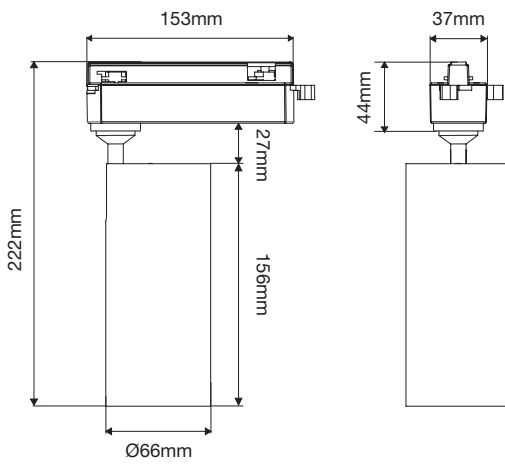

35W

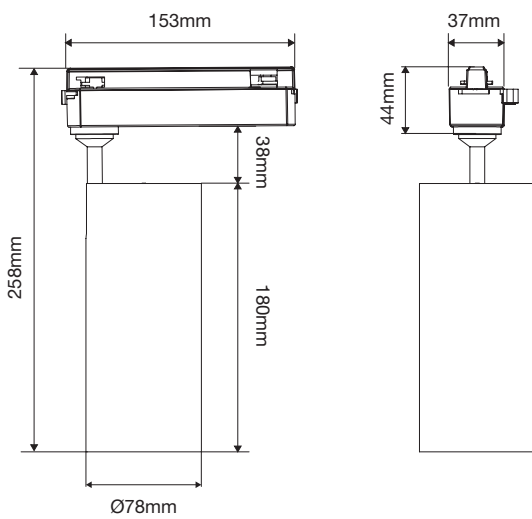

Due to the special conditions of manufacturing process of LED, the typical data of technical parameters can only reflect statistical figures and do not necessarily correspond to the actual parameters of each single product which could differ from typical data.

Exceeding maximum ratings for operation voltage will cause hazardous overload and will likely destroy the LED module.

Exceeding maximum ratings for operation and storage temperature will reduce expected life time or destroy the LED module.

Specifications are subject to change without notice. Errors and omission excepted, always make sure to use the most recent release.

LUXPOINT® LED Tracklight - Eckhard

Ordering codes

Fixture

Short Text	Wattage	CCT	Installation	Fixture Lumen	Light Source Lumen	Beam angle	Item code	EAN-13
LP TL G08 15W 830 38D 2W BL	15W	3000K	2-Wire Track	1200lm	1320lm	38°	TXGL25100047155	4897135737873
LP TL G08 15W 840 38D 2W BL	15W	4000K	2-Wire Track	1200lm	1320lm	38°	TXGL25100047255	4897135737880
LP TL G08 15W 865 38D 2W BL	15W	6500K	2-Wire Track	1200lm	1320lm	38°	TXGL25100047355	4897135737897
LP TL G08 15W 830 38D 2W WH	15W	3000K	2-Wire Track	1200lm	1320lm	38°	TXGL25100047455	4897135737903
LP TL G08 15W 840 38D 2W WH	15W	4000K	2-Wire Track	1200lm	1320lm	38°	TXGL25100047555	4897135737910
LP TL G08 15W 865 38D 2W WH	15W	6500K	2-Wire Track	1200lm	1320lm	38°	TXGL25100047655	4897135737927
LP TL G08 25W 830 38D 2W BL	25W	3000K	2-Wire Track	2000lm	2200lm	38°	TXGL25100047755	4897135737934
LP TL G08 25W 840 38D 2W BL	25W	4000K	2-Wire Track	2000lm	2200lm	38°	TXGL25100047855	4897135737941
LP TL G08 25W 865 38D 2W BL	25W	6500K	2-Wire Track	2000lm	2200lm	38°	TXGL25100047955	4897135737958
LP TL G08 25W 830 38D 2W WH	25W	3000K	2-Wire Track	2000lm	2200lm	38°	TXGL25100048055	4897135737965
LP TL G08 25W 840 38D 2W WH	25W	4000K	2-Wire Track	2000lm	2200lm	38°	TXGL25100048155	4897135737972
LP TL G08 25W 865 38D 2W WH	25W	6500K	2-Wire Track	2000lm	2200lm	38°	TXGL25100048255	4897135737989
LP TL G08 35W 830 38D 2W BL	35W	3000K	2-Wire Track	2800lm	3080lm	38°	TXGL25100048355	4897135737996
LP TL G08 35W 840 38D 2W BL	35W	4000K	2-Wire Track	2800lm	3080lm	38°	TXGL25100048455	4897135738009
LP TL G08 35W 865 38D 2W BL	35W	6500K	2-Wire Track	2800lm	3080lm	38°	TXGL25100048555	4897135738016
LP TL G08 35W 830 38D 2W WH	35W	3000K	2-Wire Track	2800lm	3080lm	38°	TXGL25100048655	4897135738023
LP TL G08 35W 840 38D 2W WH	35W	4000K	2-Wire Track	2800lm	3080lm	38°	TXGL25100048755	4897135738030
LP TL G08 35W 865 38D 2W WH	35W	6500K	2-Wire Track	2800lm	3080lm	38°	TXGL25100048855	4897135738047
LP TL G08 15W 830/840/865 38D 2W BL	15W	3000K/4000K/6500K	2-Wire Track	1200lm	1320lm	38°	TXGL25100048955	4897135738054
LP TL G08 15W 830/840/865 38D 2W WH	15W	3000K/4000K/6500K	2-Wire Track	1200lm	1320lm	38°	TXGL25100049055	4897135738061
LP TL G08 25W 830/840/865 38D 2W BL	25W	3000K/4000K/6500K	2-Wire Track	2000lm	2200lm	38°	TXGL25100049155	4897135738306
LP TL G08 25W 830/840/865 38D 2W WH	25W	3000K/4000K/6500K	2-Wire Track	2000lm	2200lm	38°	TXGL25100049255	4897135738313
LP TL G08 35W 830/840/865 38D 2W BL	35W	3000K/4000K/6500K	2-Wire Track	2800lm	3080lm	38°	TXGL25100049355	4897135738078
LP TL G08 35W 830/840/865 38D 2W WH	35W	3000K/4000K/6500K	2-Wire Track	2800lm	3080lm	38°	TXGL25100049455	4897135738085

Service contact:
 Traxon Technologies Ltd.
 Room 113, Wireless Centre, 3 Science Park East Avenue, Shatin,
 Hong Kong, China
www.traxon-ecue.com

Traxon Technologies Europe GmbH
 Karl-Schurz-Str. 38, 33100 Paderborn, Germany